

Even Flat & Thick Spray Nozzle

Hydraulic spray nozzle **DDRP series**

Due to thick flat pattern, DDRP realizes high cooling effect and water saving.
 Keep same spray angle in operation of turn down ratio **1:3**.
 Large free pass diameter for less clogging.



Applications

- **Cooling:**
Cast plate, hot rolled sheet, roll, etc.
- **Cleaning:**
Plate after acid picking, filter
- **Other:**
For applications that need effective cooling with circulated water.

■ Spray distribution

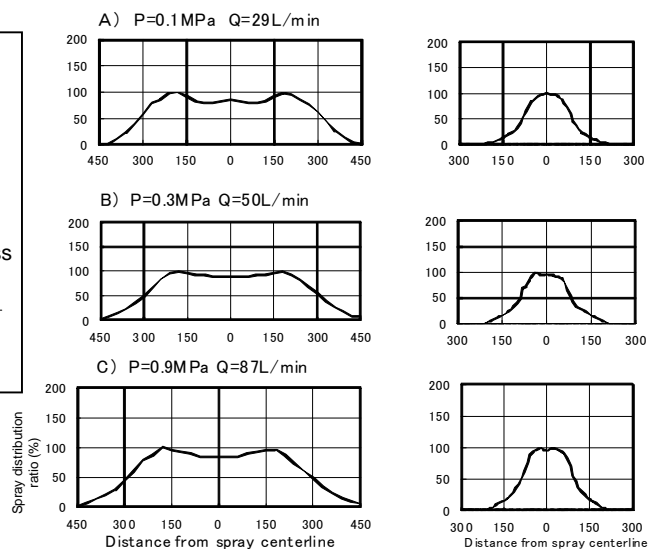
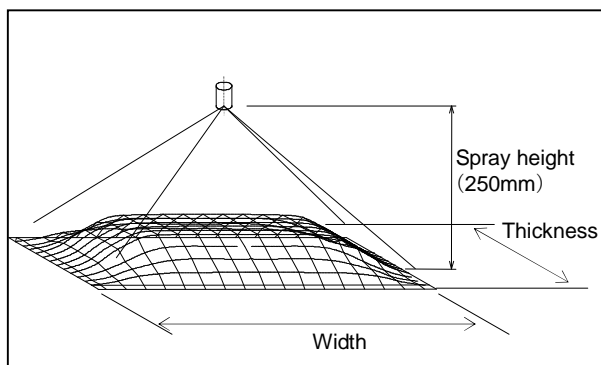

Spray distribution in width direction

Spray distribution in thickness direction

P= Pressure Q= Spray amount



“The Fog Engineers”
H. IKEUCHI & CO., LTD.

■ Specification

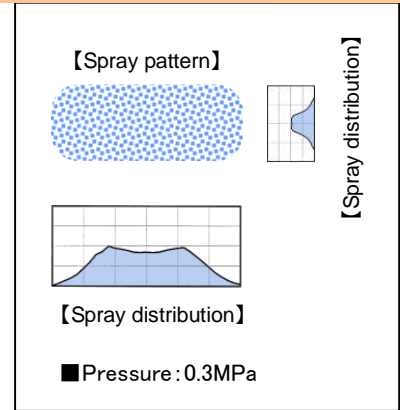
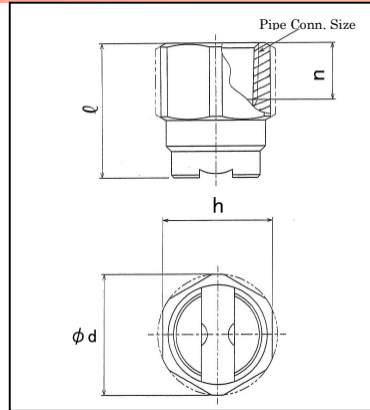
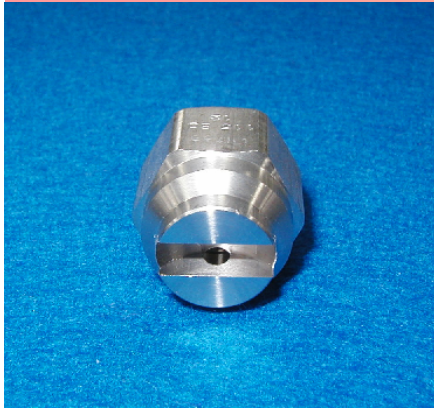

■ Dimensions

Pipe Conn. Size	Dimensions (mm)				Mass (g)
	h	d	l	n	
1/4F	19	21	21	10.5	30
3/8F	21	23	26	11	40
1/2F	26	29	32	14	80
3/4F	32	35	40	15	140
1F	41	46	48	17	300

■ Features

- Thick flat spray pattern with uniform distribution.
- Covers wide spray area with high spray impact.
- **Minimal variation in spray angle, even in 1.3 turndown ratio.**
- Minimal clogging due to large free passage diameter.

■ Material · Structure

Material: Stainless steel 303

Structure: Simple structure without using whirler.

Spray Angle Code	Width	Thickness	Spray Capacity Code	Pipe Conn. size	Spray Angle Width (°)			Spray Angle Thickness (°)			Spray Capacity (L/min)								Mean Droplet Dia. (μm)	Free Pass. Dia. (mm)										
					0.1 MPa	0.3 MPa	1 MPa	0.1 MPa	0.3 MPa	1 MPa	0.05 MPa	0.1 MPa	0.15 MPa	0.2 MPa	0.3 MPa	0.5 MPa	0.7 MPa	1 MPa			1.5 MPa	2 MPa								
115	60	50	1/4	112	115	116	58	60	60	2.15	2.98	3.61	4.13	5	6.42	7.57	9.02	11	12.7	300~390	1.4									
					113	115	116	58	60	60	4.31	5.97	7.22	8.26	10	12.8	15.1	18	22			25.3	2.0							
					113	115	116	58	60	60	5.17	7.16	8.66	9.92	12	15.4	18.2	21.6	26.4			30.4		2.2						
					113	115	116	58	60	60	6.03	8.35	10.1	11.6	14	18	21.2	25.3	30.8			35.5			2.4					
					113	115	116	58	60	60	8.62	11.9	14.4	16.5	20	25.7	30.3	36.1	44			50.7				2.9				
					113	115	116	58	60	60	11.2	15.5	18.8	21.5	26	33.4	39.4	46.9	57.2			65.9					3.3			
					113	115	116	59	60	60	12.9	17.9	21.7	24.8	30	38.5	45.4	54.1	66			76						3.5		
					113	115	116	59	60	60	21.5	29.8	36.1	41.3	50	64.2	75.7	90.2	110			127							4.5	
					113	115	116	59	60	60	34.5	47.7	57.8	66.1	80	103	121	144	176			203								5.8
					113	115	116	59	60	60	43.1	59.7	72.2	82.6	100	128	151	180	220			253								
90	45	50	1/4	88	90	90	42	45	45	2.15	2.98	3.61	4.13	5	6.42	7.57	9.02	11	12.7	310~410	1.4									
				89	90	90	42	45	45	4.31	5.97	7.22	8.26	10	12.8	15.1	18	22	25.3			2.1								
				89	90	90	43	45	45	5.17	7.16	8.66	9.92	12	15.4	18.2	21.6	26.4	30.4				2.3							
				89	90	90	43	45	45	6.03	8.35	10.1	11.6	14	18	21.2	25.3	30.8	35.5					2.5						
				89	90	90	43	45	45	8.62	11.9	14.4	16.5	20	25.7	30.3	36.1	44	50.7						2.9					
				89	90	90	43	45	45	11.2	15.5	18.8	21.5	26	33.4	39.4	46.9	57.2	65.9							3.4				
				89	90	91	43	45	45	12.9	17.9	21.7	24.8	30	38.5	45.4	54.1	66	76								3.7			
				89	90	91	43	45	45	21.5	29.8	36.1	41.3	50	64.2	75.7	90.2	110	127									4.7		
				89	90	91	43	45	45	34.5	47.7	57.8	66.1	80	103	121	144	176	203										5.9	
				89	90	91	43	45	45	43.1	59.7	72.2	82.6	100	128	151	180	220	253											6.7

■ How to order

Please inquire or order for a specific nozzle using this coding system.

Exam. 1/4FDDR1156050S303

1/4F	DDRP	115	60	50	S303
Pipe Conn. Size	Series	Spray Angle Code (Width)	Spray Angle Code (Thickness)	Spray Capacity Code	Material
1/4F	-	115	60	50	-
~		90	45	~	
1F				1000	

"The Fog Engineers"
H. IKEUCHI & CO., LTD.

ISO9001:2008 certified

Headquarters

Daiichi Kyogyo Bldg., 1-15-15, Awaza
Nishi-ku, Osaka 550-0011, Japan
Tel: 81-6-6538-4015 Fax: 81-6-6538-4022
E-mail: overseas@kirinoikeuchi.co.jp
URL: http://www.kirinoikeuchi.co.jp/eng/

IKEUCHI (SHANGHAI) CO., LTD.

Room C, 21/F, Electrical & Mechanical Bldg., 600 Hengfeng Road, Shanghai 200070, P.R.China
Tel: 86-21-6140-9731 Fax: 86-21-6123-4239 E-mail: mist@kirinoikeuchi.com URL: http://www.kirinoikeuchi.com/
Tianjin Branch Tel: 86-22-2320-1676 Fax: 86-22-2320-1675

IKEUCHI USA, INC.

8110 Beckett Center Drive, West Chester, OH 45069 USA
Tel: 1-513-942-3060 Fax: 1-513-942-3064 E-mail: info@ikeuchiusa.com URL: http://www.ikeuchiusa.com/

IKEUCHI EUROPE B.V.

Asterweg 17 A6, 1031 HL Amsterdam, The Netherlands
Tel: 31-20-820-2175 Fax: 31-20-820-2176 E-mail: info@ikeuchieurope.com URL: http://www.ikeuchieurope.com/

IKEUCHI TAIWAN CO., LTD.

11 F-1, No.27, Sec.1, Chung Shan N. Rd., Taipei, 10441 Taiwan, R.O.C.
Tel: 886-2-2511-6289 Fax: 886-2-2541-6392 E-mail: sales@ikeuchi.com.tw URL: http://www.ikeuchi.com.tw/

PT. IKEUCHI INDONESIA

Ruko Easton Jalan Gunung Panderman Blok E No.9, Lippo Cikarang Kel. Cibatu Kec., Cikarang Selatan Bekasi 17550 Indonesia
Tel: 62-21-2909-3246 Fax: 62-21-2909-3247 E-mail: sales@ikeuchi.co.id URL: http://www.kirinoikeuchi.co.jp/ikj/